

Space Flight Operations Contract

Location Coding Workbook Loc Code 21002

Advanced Training Series

**For Training Purposes Only
Systems Division
EVA & Crew Systems Operations Branch**

June 17, 2004

Contract NAS9-20000



Location Coding Workbook
Loc Code 21002

Prepared by

Original approval obtained

Rob Tomaro
USA/Book Manager

Approved by

Original approval obtained

Adam Flagan
Technical Lead Shuttle Crew Systems Group

Original approval obtained

Jude Alexander, Manager
Crew Systems and Photo/TV Group

REVISION LOG

Rev. letter	Change no.	Description	Date
Basic	A B	Revision A Revision B	06/1996 06/17/2004

LIST OF EFFECTIVE PAGES

The status of all pages in this document is shown below:

<u>Page No.</u>	<u>Change No.</u>
Preface	Rev. B
Foreword	Rev. B
How To Use This Workbook	Rev. B
i – ii	Rev. B
1-1	Rev. B
2-1 – 2-5	Rev. B
3-1 – 3-11	Rev. B
4-1 – 4-3	Rev. B
5-1 – 5-2	Rev. B

PREFACE

The Location Coding Workbook Loc Code 21002 was prepared by the United Space Alliance (USA), Flight Operations.

The primary responsibility is with USA, Crew Systems D/43220.

Questions concerning the technical content of this document should be directed to Name, Phone Number, Mailcode, Department Number (example: D/4220).

Rob Tomaro (281) 483-3810, DX33, D/43220

FOREWORD

Original Developer	Kim Kennedy
Book Manager	Rob Tomaro
Branch	EVA, and Crew Systems Operations
Mail Code	DX33
Telephone	281-483-3810
Location	Building 4 North

This training material is part of a series of lectures, handouts, and workbooks for instruction on crew systems.

This training package should be studied before attending any classroom session on this material or taking any lesson for which this is a prerequisite.

The Crew Systems lesson sequence chart shows where this lesson fits in the series, the prerequisites for each lesson, and the optimum presentation order. The lesson sequence charts are located in the Shuttle Training Program catalog.

This material is for training purposes only; it should not be used as a source of operational data.

The last page in this workbook is the Lesson Critique Sheet, which is used to obtain your comments on this workbook. Please fill it out and mail to the instructor when you have completed this workbook. (It need not be placed in an envelope nor be signed.)

HOW TO USE THIS WORKBOOK

This book is organized into sections. You should proceed through the sections in the order they are presented. Within the section, however, you control your own progress. You should begin each section by reading the objective and the learning material. The learning material is set apart in a box. This is the central information to be learned. Supporting data following the learning material is provided as additional information to aid you in learning. If you are already quite familiar with the material presented in the learning material, skip right to the next sections. For other sections, with which you are somewhat familiar, you may want to read the objective, learning material, and some of the supporting data, then go to the exercise. If the material is totally new to you, most of the supporting data should be very helpful.

This workbook is provided for your use. You may make notes or write comments anywhere you like. You may retain the text for later reference.

CONTENTS

Section	Page
1.0 ORBITER CREW COMPARTMENT CODES.....	1-1
1.1 INTRODUCTION.....	1-1
1.2 LOCATION CODE FORMATS.....	1-1
1.2.1 Examples of Orbiter Codes	1-1
2.0 FLIGHT DECK LOCATION CODES	2-1
2.1 INTRODUCTION.....	2-1
2.2 ORBITER FLIGHT DECK LOCATION CODING	2-1
3.0 MIDDECK LOCATION CODES	3-1
3.1 INTRODUCTION.....	3-1
3.2 ORBITER MIDDECK LOCATION CODING	3-1
4.0 AIRLOCK LOCATION CODES.....	4-1
4.1 INTRODUCTION.....	4-1
4.2 ORBITER AIRLOCK LOCATION CODING	4-1
5.0 PRACTICE EXERCISE	5-1
5.1 PRACTICE EXERCISE ANSWERS.....	5-2

FIGURES

Figure

1	Crew cabin (cutaway view).....	ii
2-1	Flight deck location codes	2-3
2-2	Forward flight deck equipment.....	2-4
2-3	Aft flight deck equipment and location codes.....	2-5
3-1	Middeck location codes (1 of 7).....	3-3
3-2	Forward middeck cutaway.....	3-10
3-3	Aft middeck cutaway.....	3-11
4-1	Airlock location codes.....	4-2
4-2	Airlock equipment and associated location codes	4-3

LESSON INTRODUCTION

The orbiter location codes enable crewmembers to locate displays and controls, stowage compartments and lockers, access panels, and wall mounted equipment in the orbiter crew compartment. The codes are referenced in various forms of the shuttle documentation, including the procedural checklists, and are used extensively during shuttle preflight activities to define the orbiter equipment locations. The orbiter crew compartment is divided into areas known as the flight deck, middeck, and airlock. A fourth compartment, the SpaceHab, is part of the shuttle configuration when the SpaceHab module is flown. The SpaceHab location coding is shown in the SpaceHab Habitability Workbook (S Hab 2102). Because of compartment functions and geometry, each has a unique location-coding format.

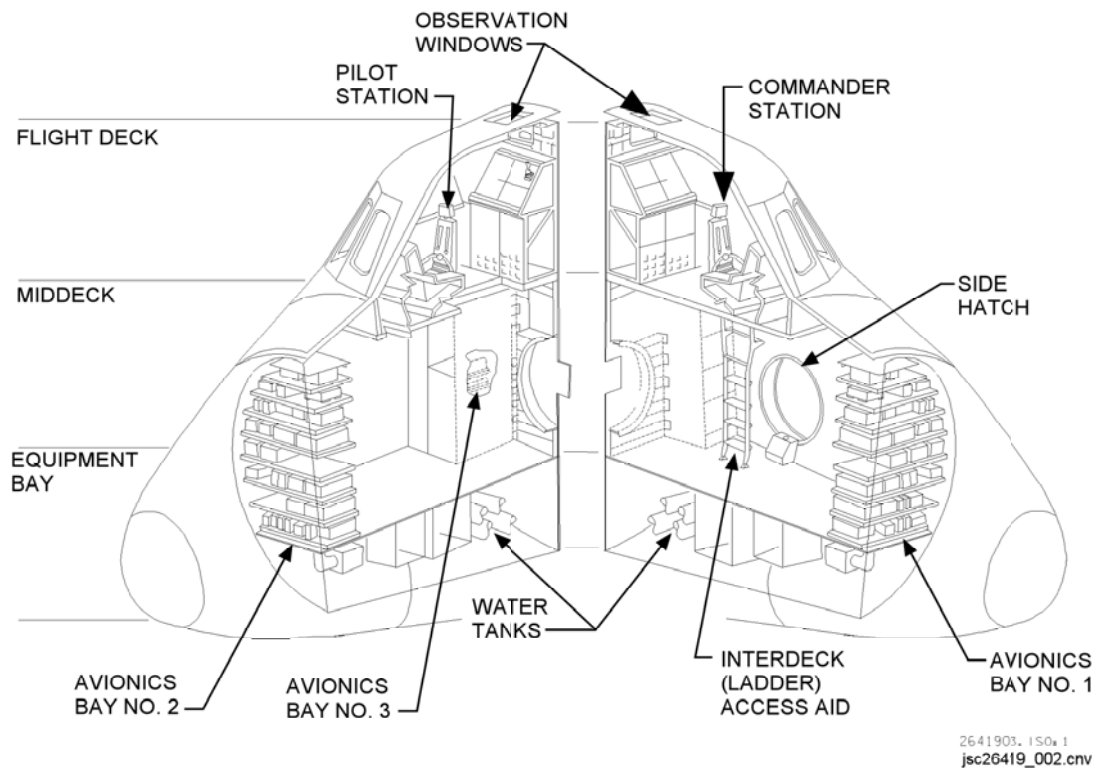

Figure 1. Crew cabin (cutaway view)

1.0 ORBITER CREW COMPARTMENT CODES

1.1 INTRODUCTION

Each area of the crew compartment (flight deck, middeck, and airlock) has a unique location-coding format.

1.2 LOCATION CODE FORMATS

Flight deck	A two- (or three-) character alphanumeric code. The first character is a letter, and the second (and third) character is a number. The code may also be further expanded to call out upper/lower areas of a panel location with the characters U and L attached to the end
Middeck	A five-character alphanumeric code starting with M
Airlock	A four- or five-character alphanumeric code starting with A

1.2.1 Examples of Orbiter Codes

a. Flight deck codes (two or three characters)

S1
L12
F6
A6L
R11U
O5

b. Middeck codes (four or characters)

MF43C
MA16N
ML60J
MO52J
MD73R

c. Airlock codes (four or five characters)

AW82H
AO4F
AD2F

2.0 FLIGHT DECK LOCATION CODES

2.1 INTRODUCTION

A flight deck location code consists of two or three alphanumeric characters (Figure 2-1).

Note: Sometimes an additional U or L is attached to the end of the code to call out the upper or lower halves respectively. This would expand the code out to three or four characters.

The forward flight deck contains the commander and pilot stations with the displays and controls (D&C) necessary to monitor, command, and control the orbiter and orbiter systems during normal and contingency operations (Figure 2-2). The forward flight deck also contains stowage provisions for the flight data file.

The aft flight deck contains D&C required to perform orbiter systems management, on-orbit maneuvers, payload systems management, and payload handling operations (Figure 2-3). The aft flight deck also contains stowage provisions for crew equipment that must be accessed during early on-orbit operations.

2.2 ORBITER FLIGHT DECK LOCATION CODING

The characters in the flight deck codes specify the following:

- First character – The first letter of a flight deck surface; the characters and surfaces are

L – Left	C – Center console
R – Right	O – Overhead
F – Forward	S – Seats
A – Aft	W – Windows

(The surfaces are addressed while sitting in the Commander/Pilot (CDR/PLT) seats)

- Second/third characters – Numerics identifying the relative location of components on each flight deck surface

Exceptions:

- Third/fourth characters – Letters that further divide the flight deck surface into upper or lower halves: U – Upper; L – Lower

Note: Sometimes the installation codes are used in place of upper/lower; for example, A1 – Upper; A2 – Lower.

The following table contains the general numbering philosophy (second/third characters) for the flight deck surfaces:

Surfaces	General numbering philosophy
L – Left R – Right C – Center console	<ul style="list-style-type: none"> Numbered from top to bottom, forward to aft
O - Overhead	<ul style="list-style-type: none"> Numbered from left to right, forward to aft
F – Forward A – Aft	<ul style="list-style-type: none"> Numbered from left to right, top to bottom (facing the surface)
W – Windows	<ul style="list-style-type: none"> The forward windows are numbered left to right (W1 through W6) facing forward The overhead windows are numbered left to right (W7 and W8) facing aft The aft windows are numbered left to right (W9 and W10) facing aft
S – Seats	<ul style="list-style-type: none"> The CDR's seat is <u>S1</u> and the PLT's seat is <u>S2</u>

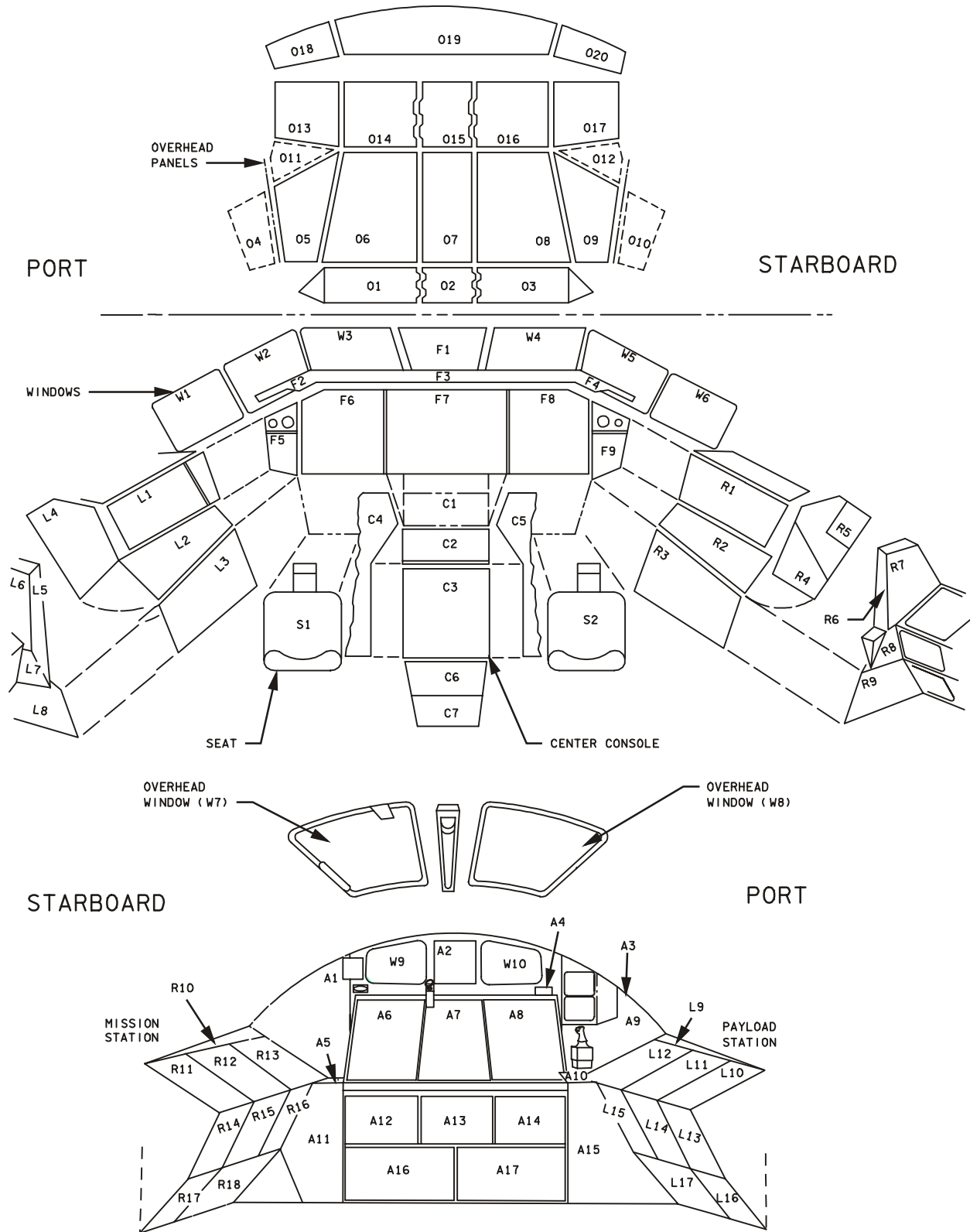

2641906. ART# 3

Figure 2-1. Flight deck location codes

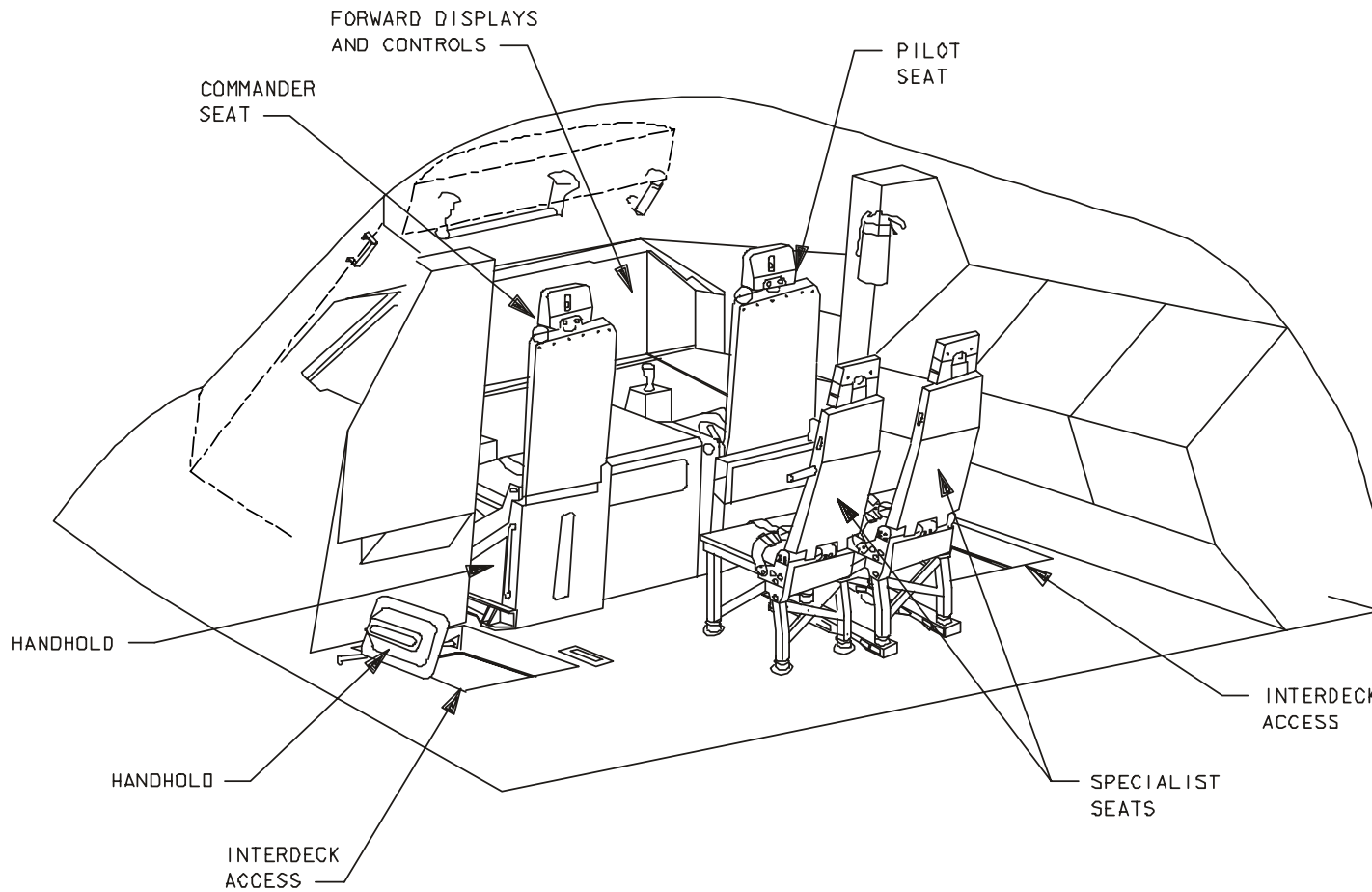

2641902. ISO 2

Figure 2-2. Forward flight deck equipment

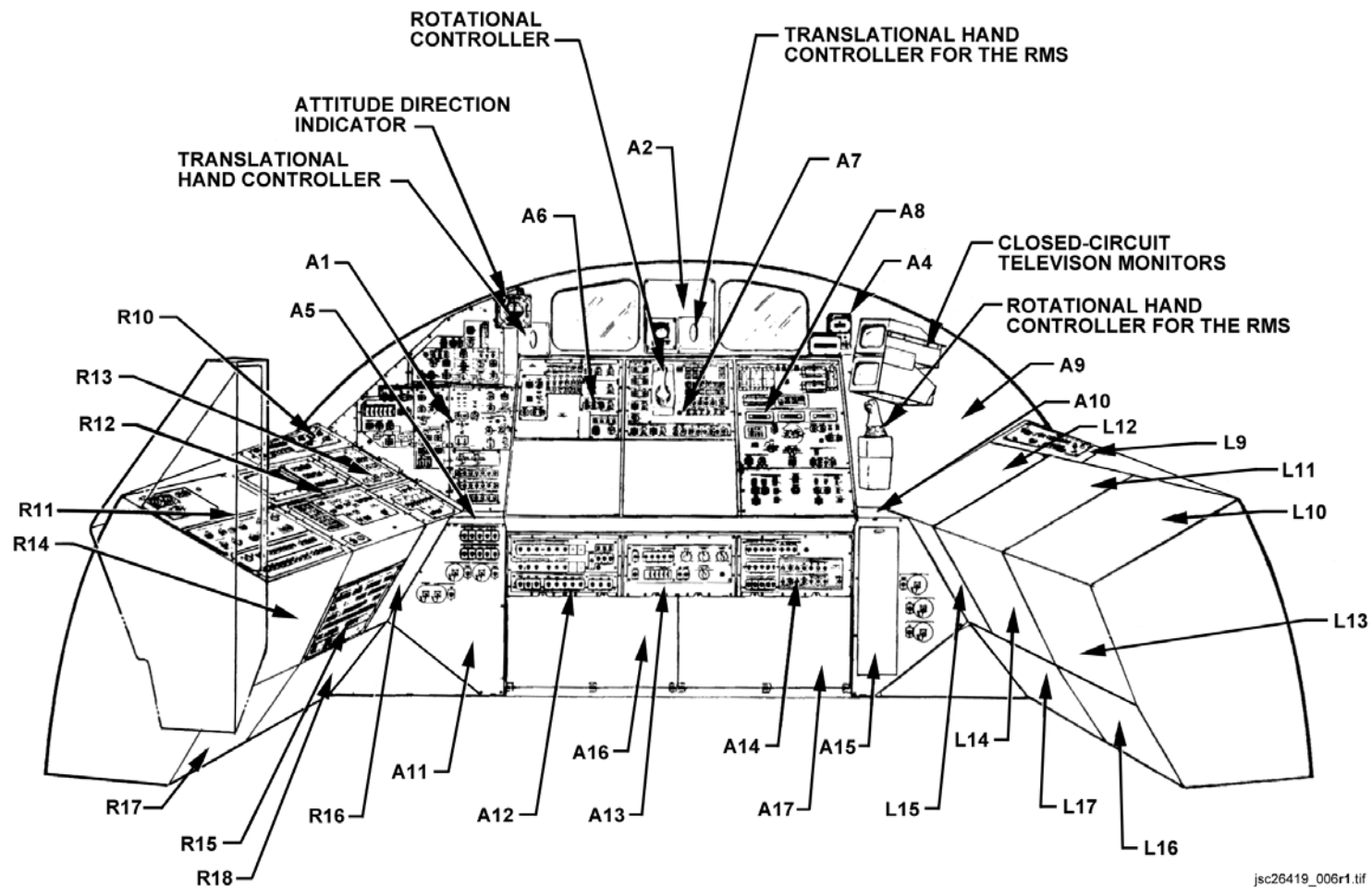

jsc26419_006r1.tif

Figure 2-3. Aft flight deck equipment and location codes

3.0 MIDDECK LOCATION CODES

3.1 INTRODUCTION

The middeck location codes have four or five alphanumeric characters starting with M.

The orbiter middeck contains D&C panels for orbiter systems control, stowage provisions for most of the crew equipment on a flight, a waste management system (WMS) compartment, the airlock, and middeck floor stowage compartments (Figure 3-1, Figure 3-2, and Figure 3-3). Beneath the middeck, the lower equipment bay contains environmental control and life support system (ECLSS) hardware. Access to equipment in the lower equipment bay is through middeck floor panels, which are marked with middeck codes.

Note: The panel numbers listed below are not consistent with the location coding system defined by this document. However, in each case the location coding, as indicated, is in close proximity to the actual location. The panel numbers below were assigned prior to middeck closeout panel design definition. The starting points for location coding were behind the closeout panels, whereas the starting points used in this document are in front of the closeout panels.

ML31C	MA73C	MO30F	MO29J	MO62M
ML86B	MO58F	MO52J	MO39M	MO13Q

3.2 ORBITER MIDDECK LOCATION CODING

The characters in the middeck codes specify the following:

- First character – M for middeck.
- Second character – The first letter of a middeck surface; the characters and surfaces are

L – Left	A – Aft
R – Right	D – Deck
F – Forward	O – Overhead

The reference position for identifying the surface is standing on the middeck floor (deck) facing forward (+X).

- Third/fourth/fifth characters – These characters form a location grid on each middeck surface.

The third and fourth characters are numerics indicating the distance from the left* side of a surface expressed as a percentage of the total width of the surface (follows the contour of the wall).

The last character is an alpha character indicating the distance from the top* of a surface expressed alphabetically in increments of 6 inches.

MOD standards do not utilize the letter “i”.

*Each surface is addressed as follows to determine the “left” and “top” sides.

Surfaces	Reference position
L, R, F, A	Standing on deck facing the surface
D	Standing on deck facing forward (+X) looking down
O	The overhead location grid matches the grid on the deck; i.e., a point on the overhead has the same third, fourth, and fifth characters as a point directly below it on the deck

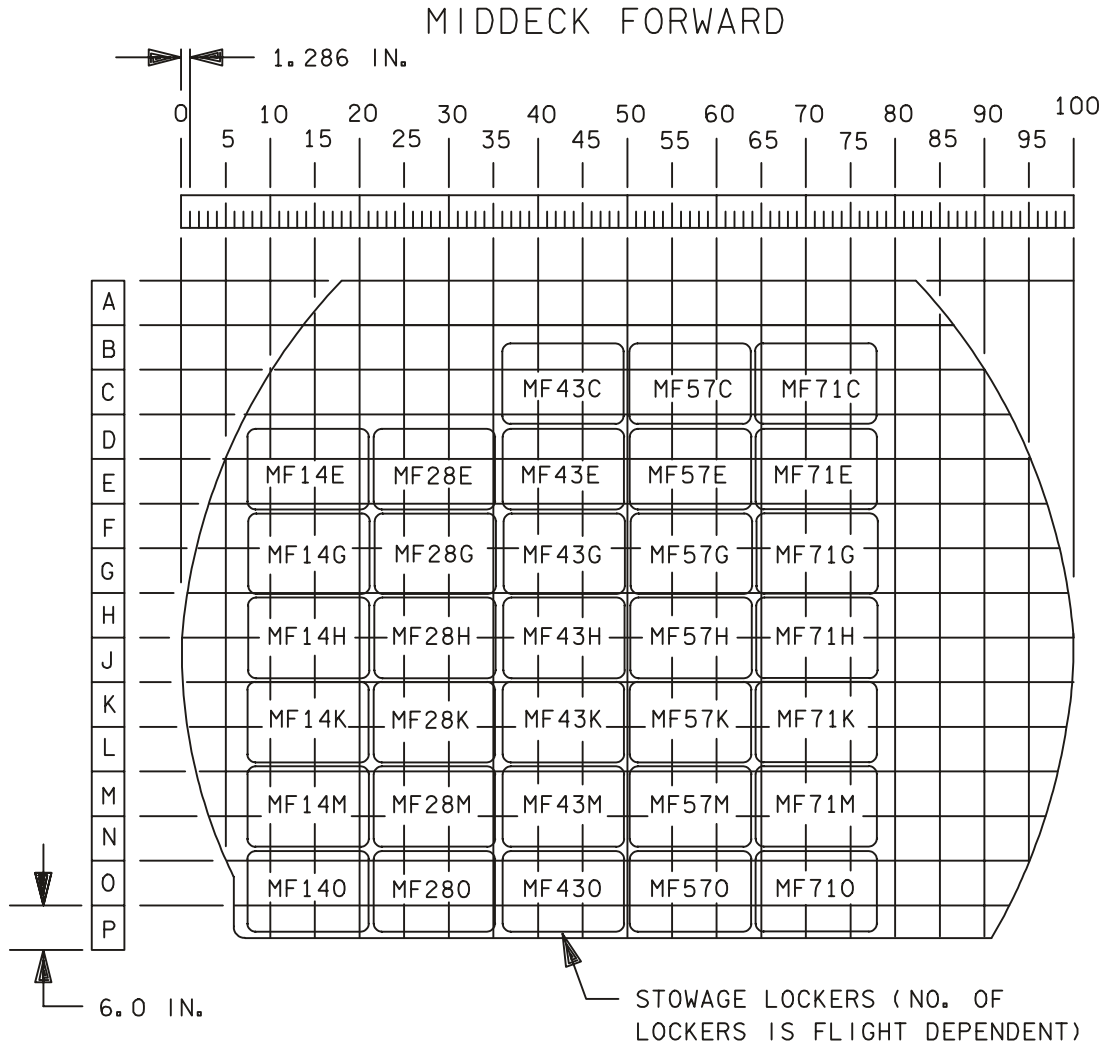

2641910. ART# 1

Figure 3-1. Middeck location codes (1 of 7)

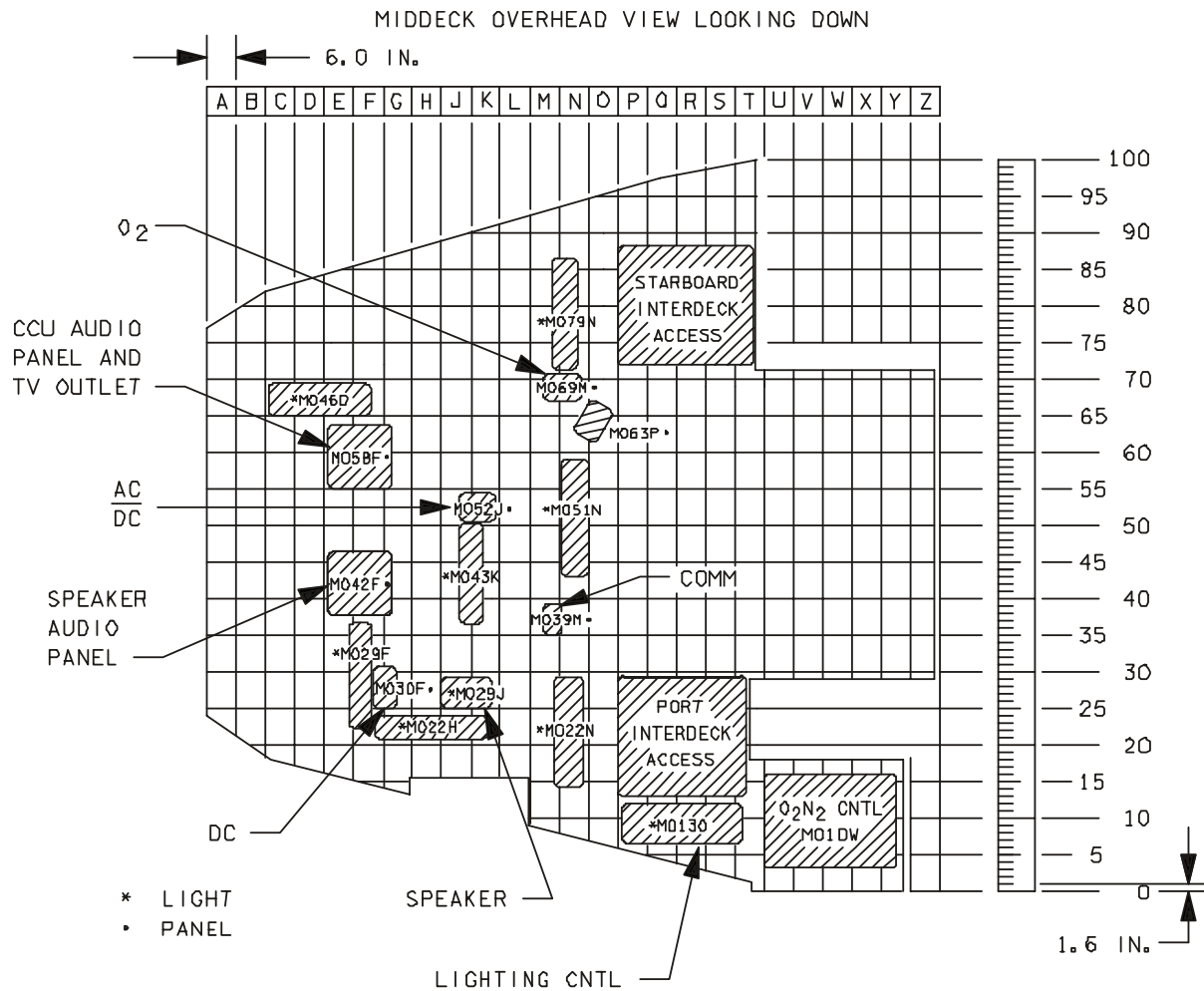

2641909. ART 1

Figure 3-1. Continued (2 of 7)

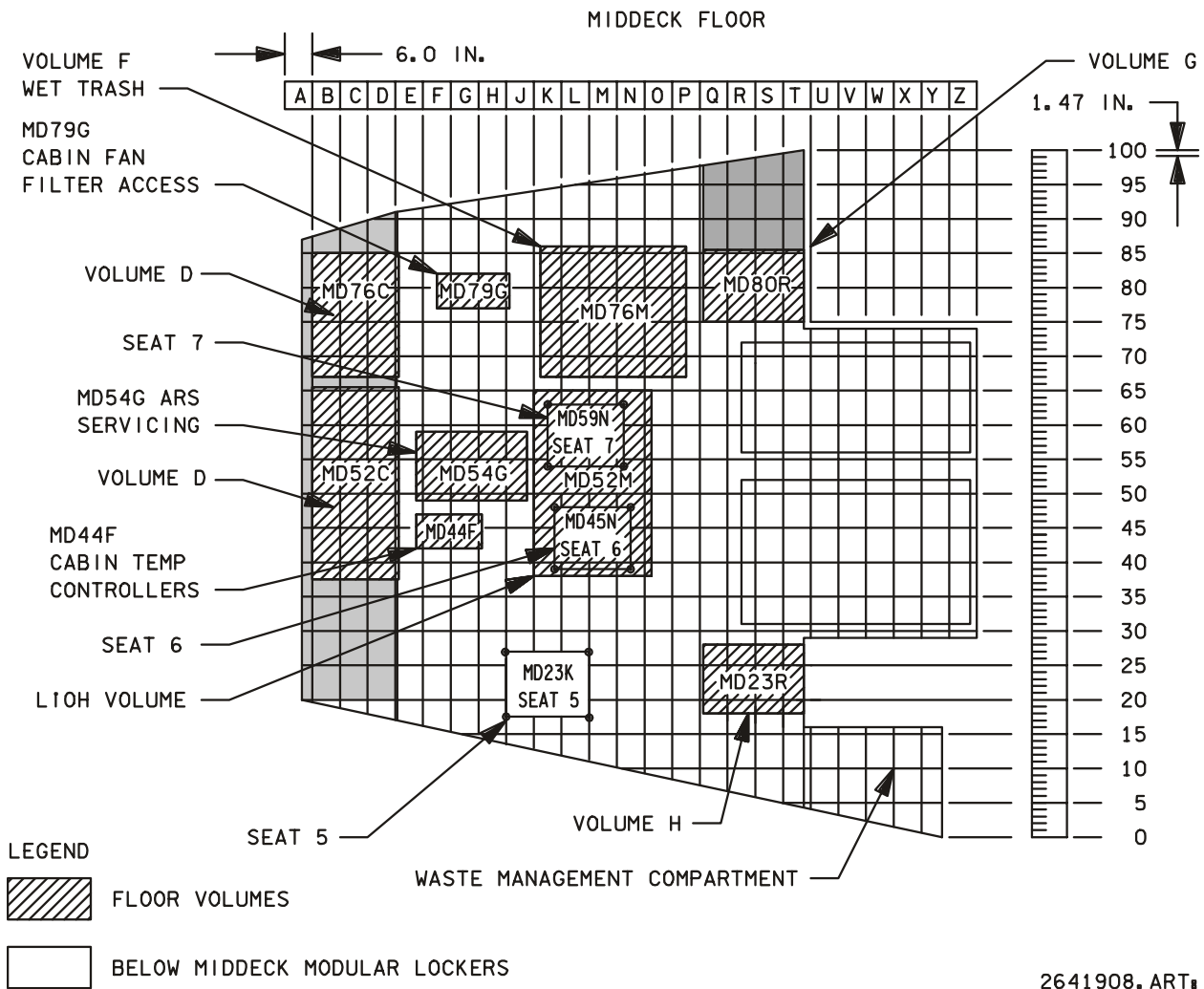

2641908.ART# 1

Figure 3-1. Continued (3 of 7)

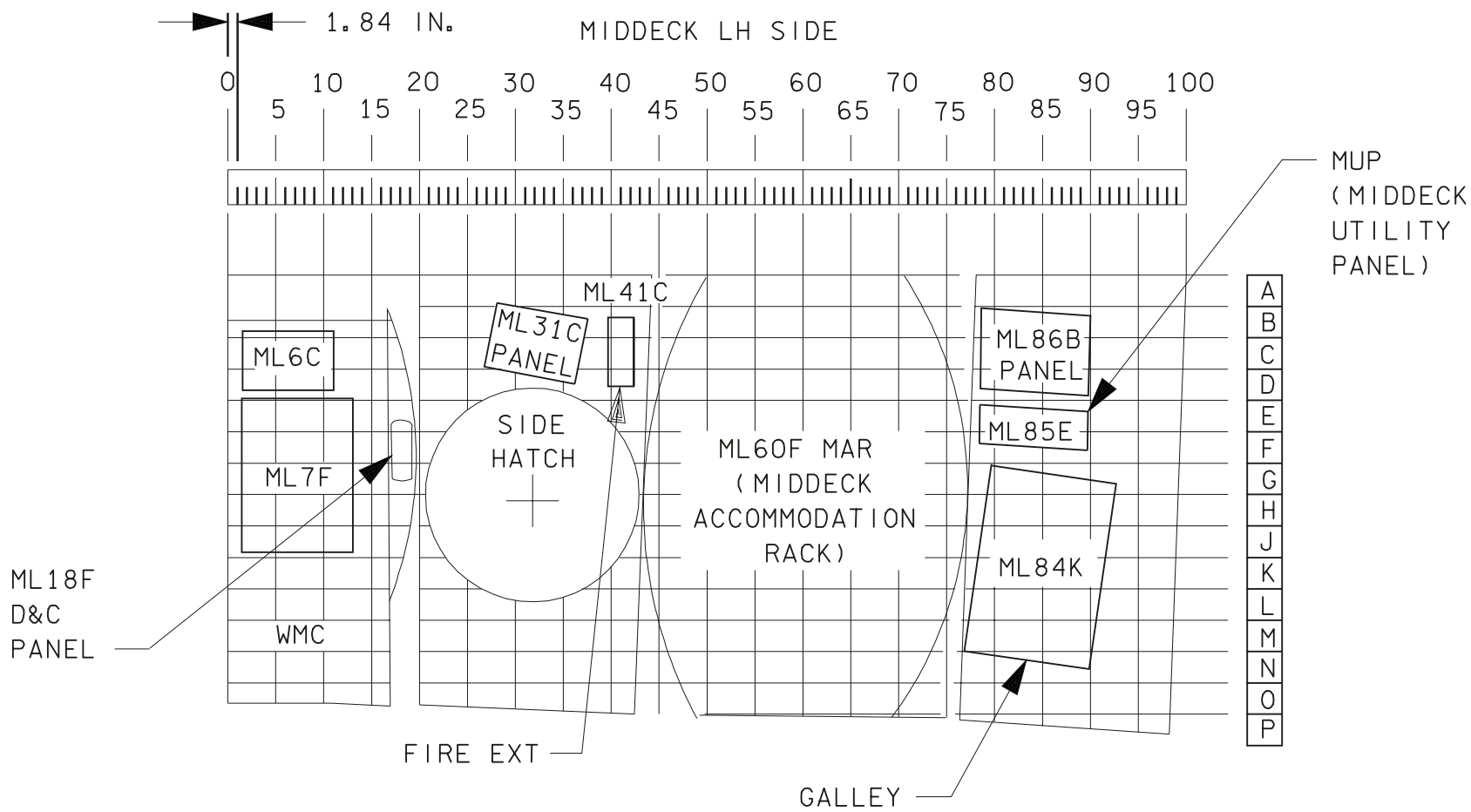

2641907. ART, 1

Figure 3-1. Continued (4 of 7)

MIDDECK RH SIDE

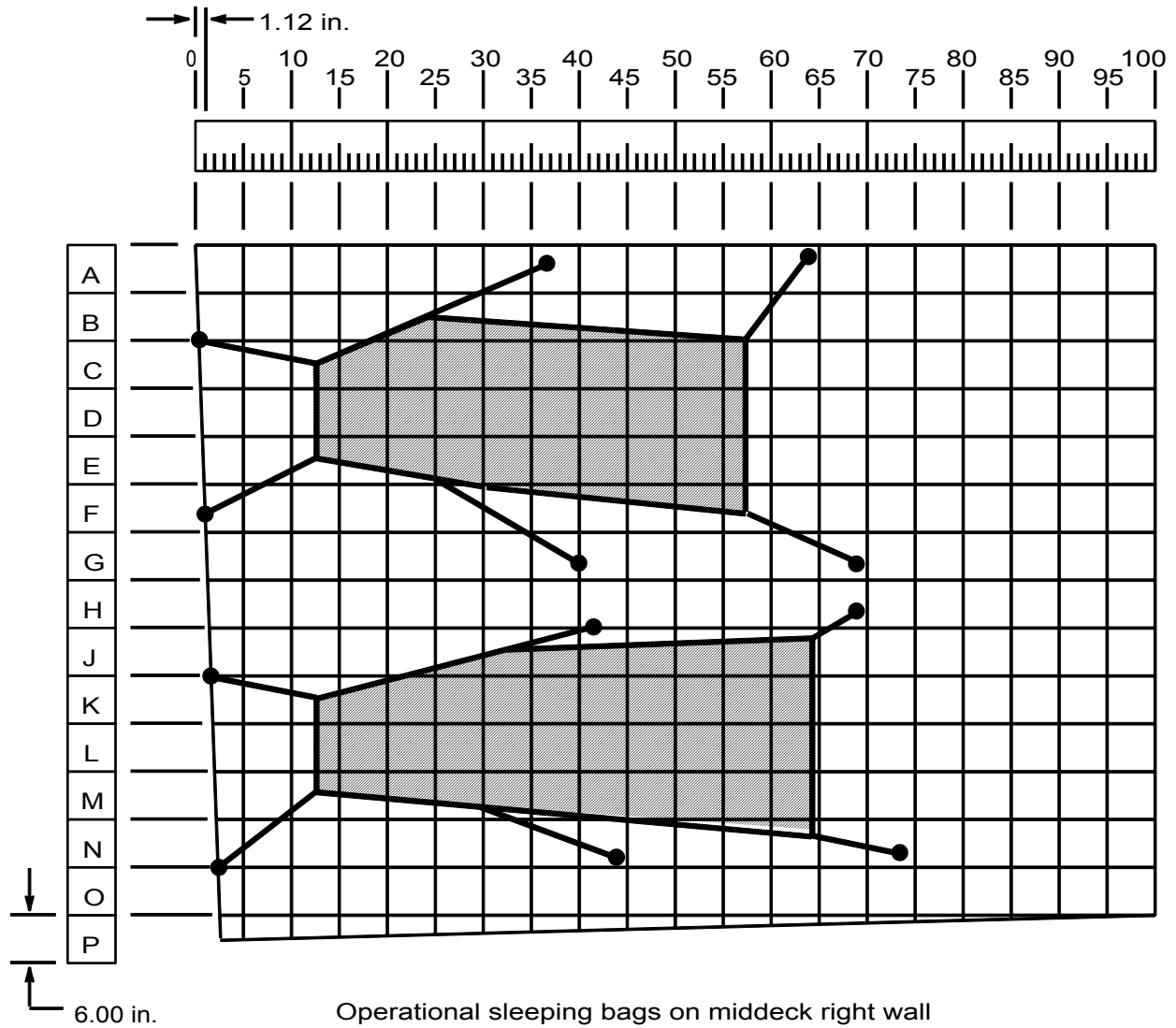

j_26419_002

Figure 3-1. Continued (5 of 7)

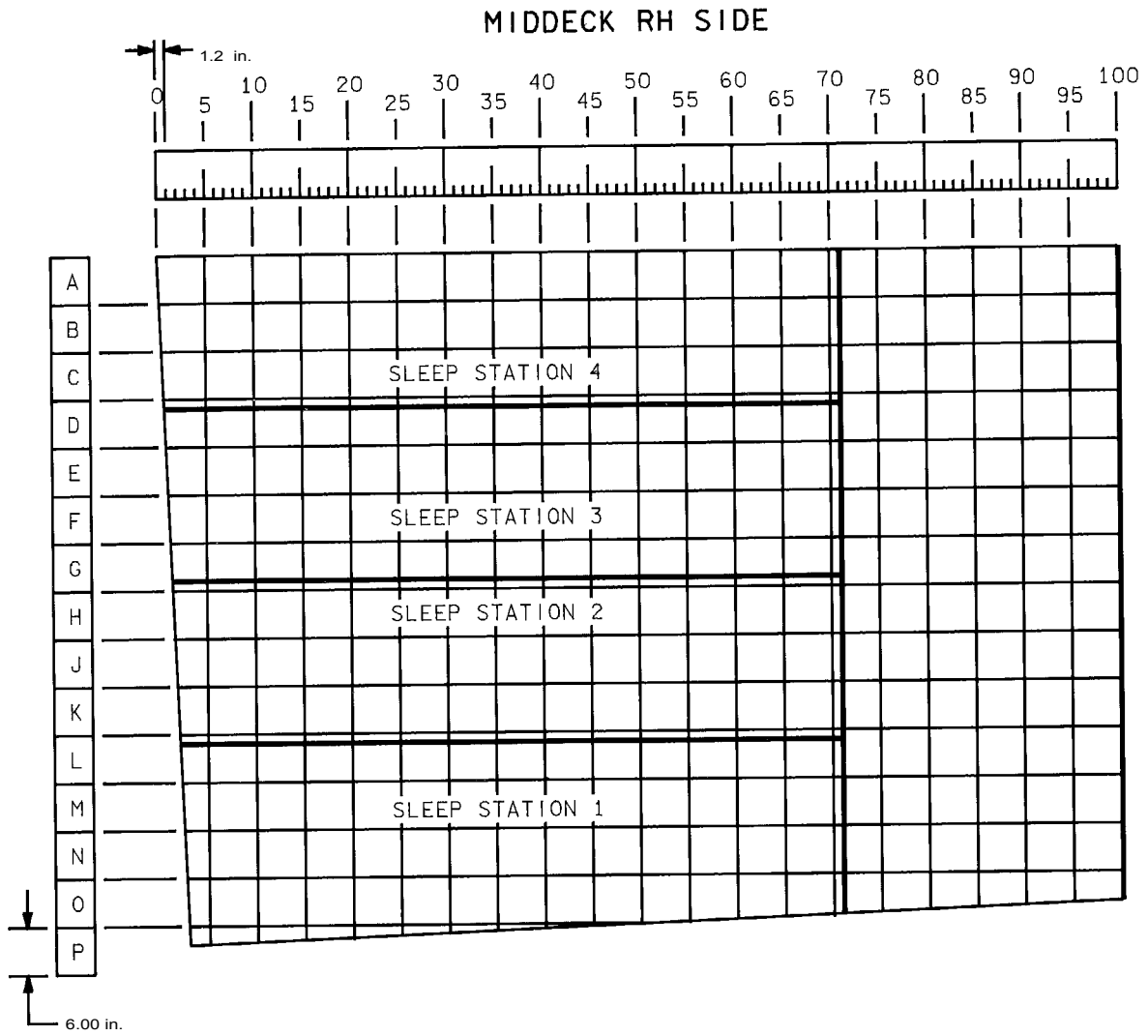

Four-tier sleep station on middeck right wall

j_26419_013

Figure 3-1. Continued (6 of 7)

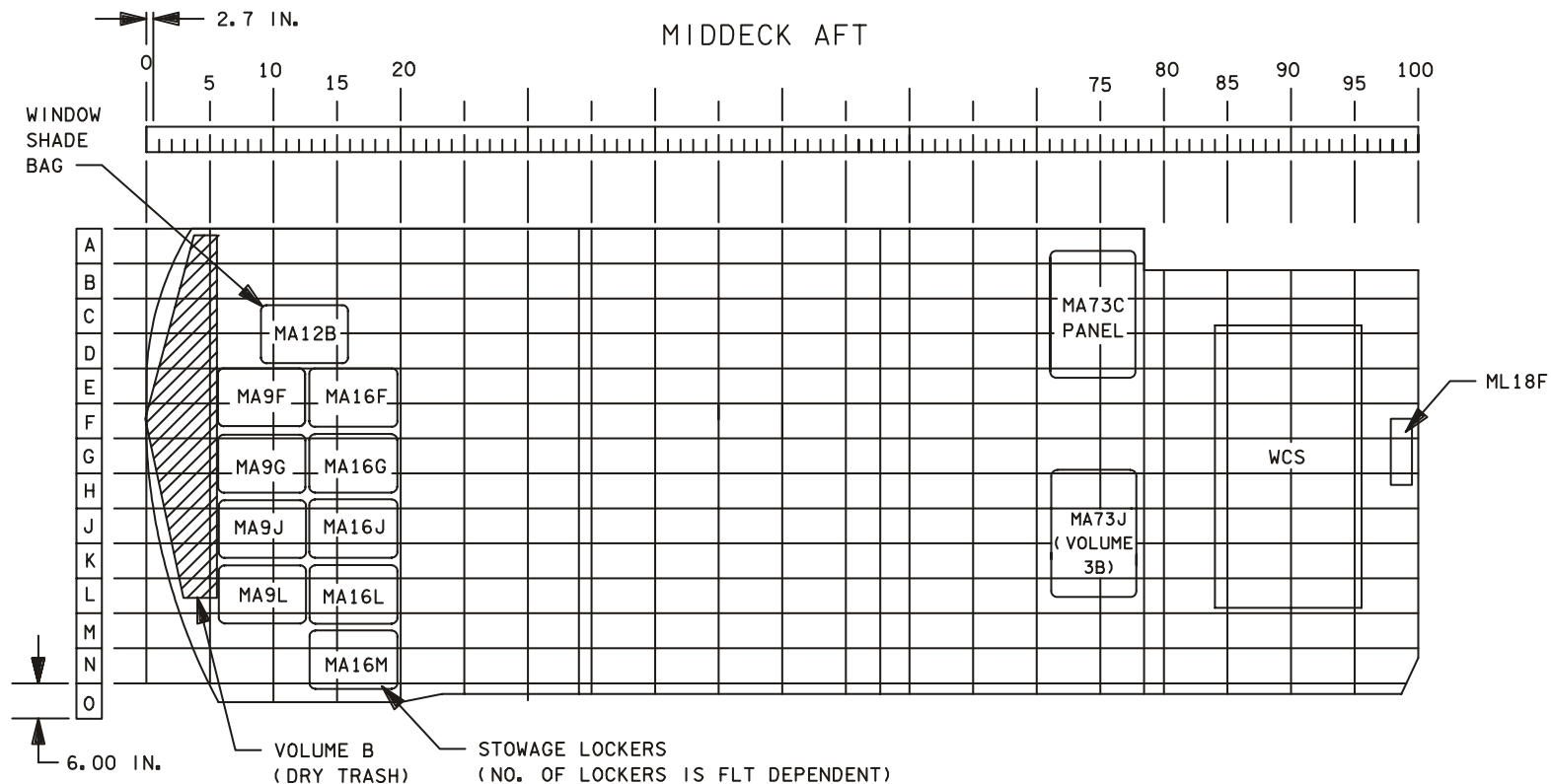

2641911. ART# 1

Figure 3-1. Continued (7 of 7)

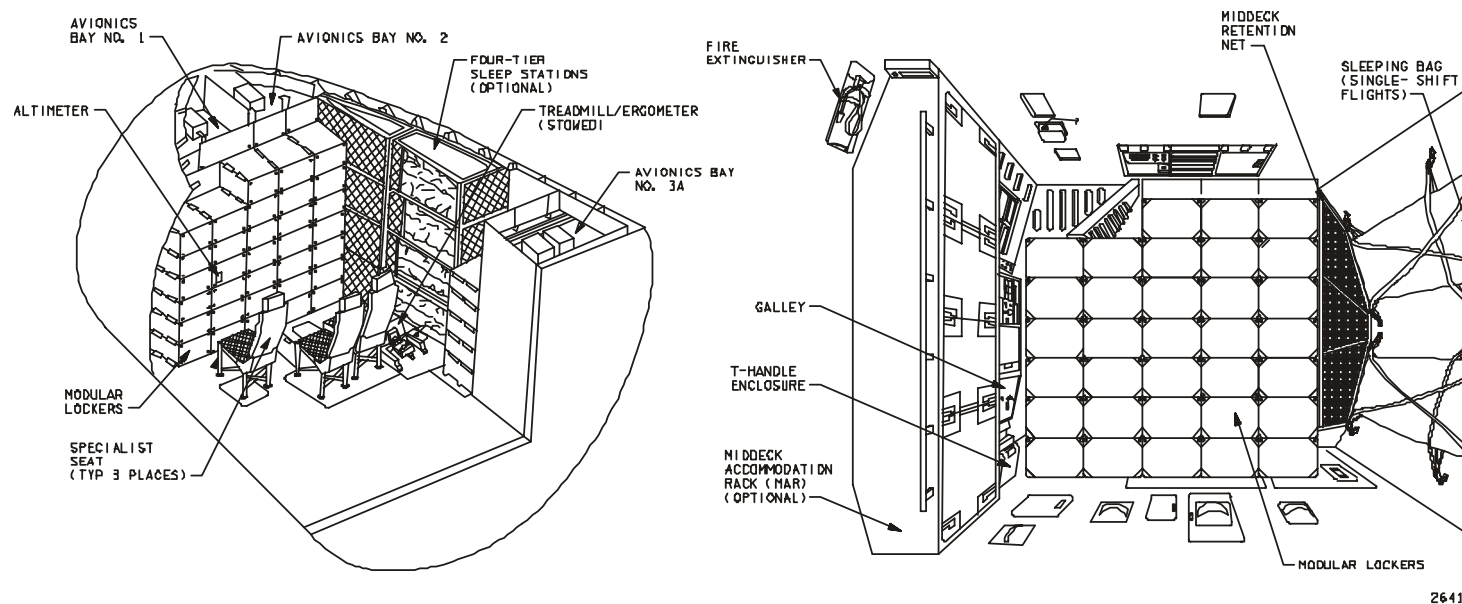
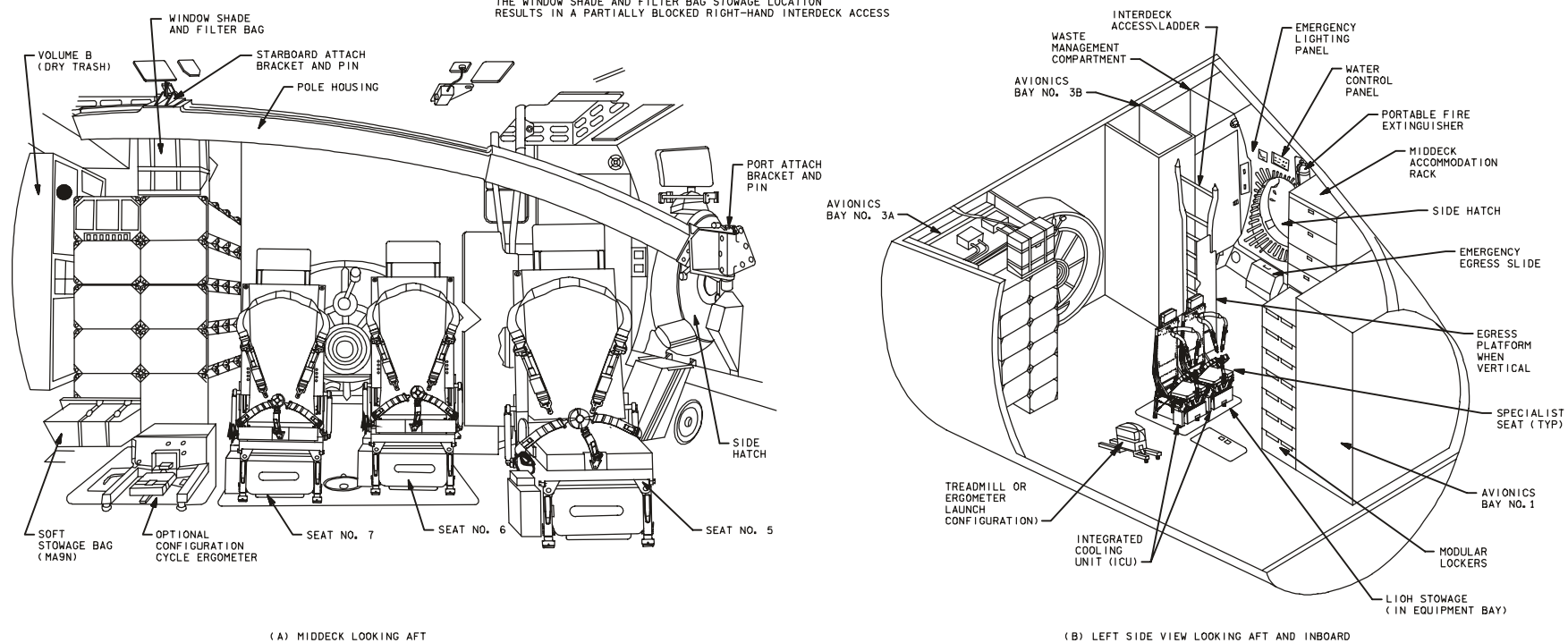

Figure 3-2. Forward middeck cutaway

CAUTION

THE WINDOW SHADE AND FILTER BAG STOWAGE LOCATION RESULTS IN A PARTIALLY BLOCKED RIGHT-HAND INTERDECK ACCESS



(A) MIDDECK LOOKING AFT

(B) LEFT SIDE VIEW LOOKING AFT AND INBOARD

2641904, ISO 4

Figure 3-3. Aft middeck cutaway

4.0 AIRLOCK LOCATION CODES

4.1 INTRODUCTION

An airlock code consists of four or five alphanumeric characters (Figure 4-1 and Figure 4-2).

The airlock provides the capability to transfer from the middeck to the payload bay for extravehicular activity (EVA) without depressurizing the orbiter cabin. The airlock has D&C panels for airlock systems control and stowage provisions for most of the crew equipment necessary to perform an EVA.

4.2 ORBITER AIRLOCK LOCATION CODING

The characters in the airlock codes specify the following:

- First character – A for airlock
- Second character – The first letter of an airlock surface; the characters and surfaces are

W - Wall
O - Overhead
D - Deck

The “wall” is the inner wall of the cylindrical airlock. The airlock is oriented upside down with respect to the middeck, so that the airlock overhead corresponds to the middeck floor. The “overhead” surface is honeycomb material with the sub floor volume containing Docking System Avionics. The “Deck” surface is the ODS Hatch. The wall location codes have five characters and the overhead/deck codes have four characters.

- Third/fourth/fifth characters (wall only) – These characters form a location grid on the airlock wall.

The third and fourth characters are numerics indicating the distance (clockwise) from the vertical centerline of the forward hatch expressed as a percentage of the total airlock circumference.

The fifth character is an alpha character indicating the distance from the overhead surface expressed alphabetically in increments of 6 inches.

- Third/fourth characters (overhead/deck only) – These alpha (A through K) numeric (0 through 10) characters form location grids on the deck and overhead surfaces. Since these surfaces are small, items can be easily located without the aid of the location grids.

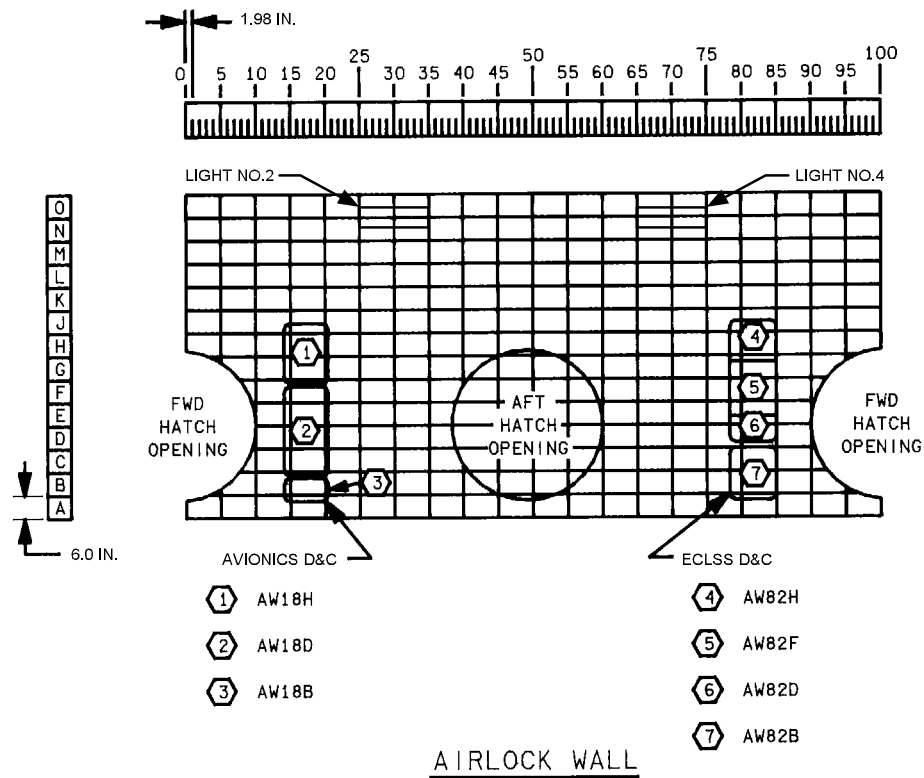
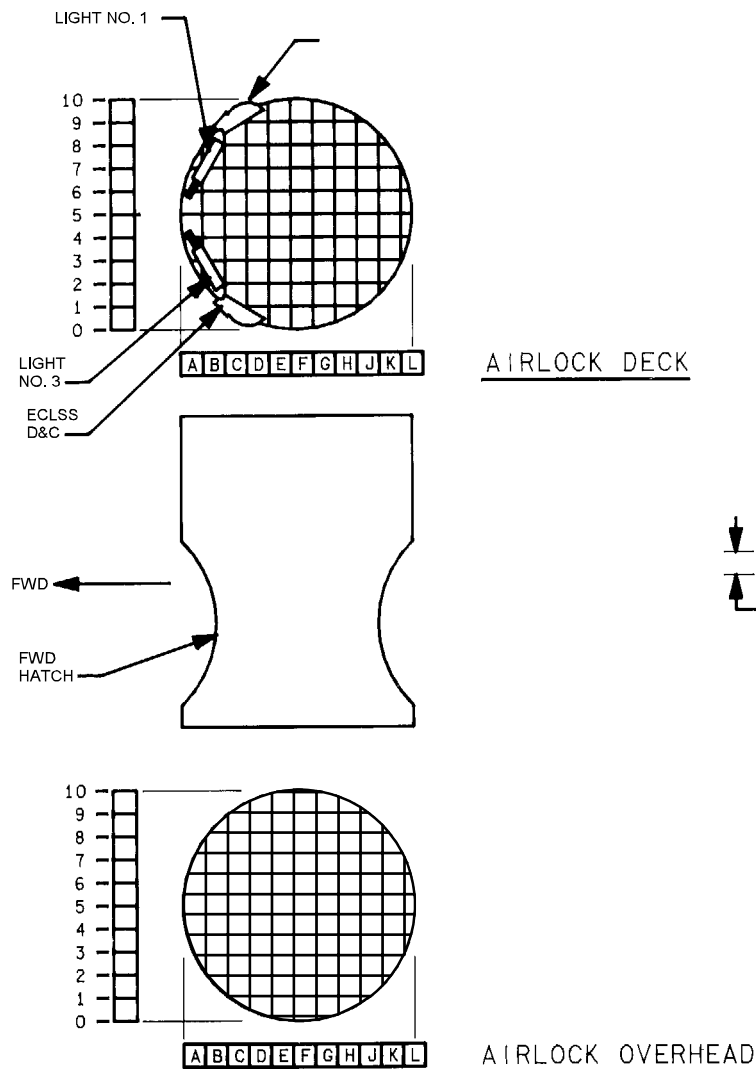

Figure 4-1. Airlock location codes

jsc26419_017.cnv

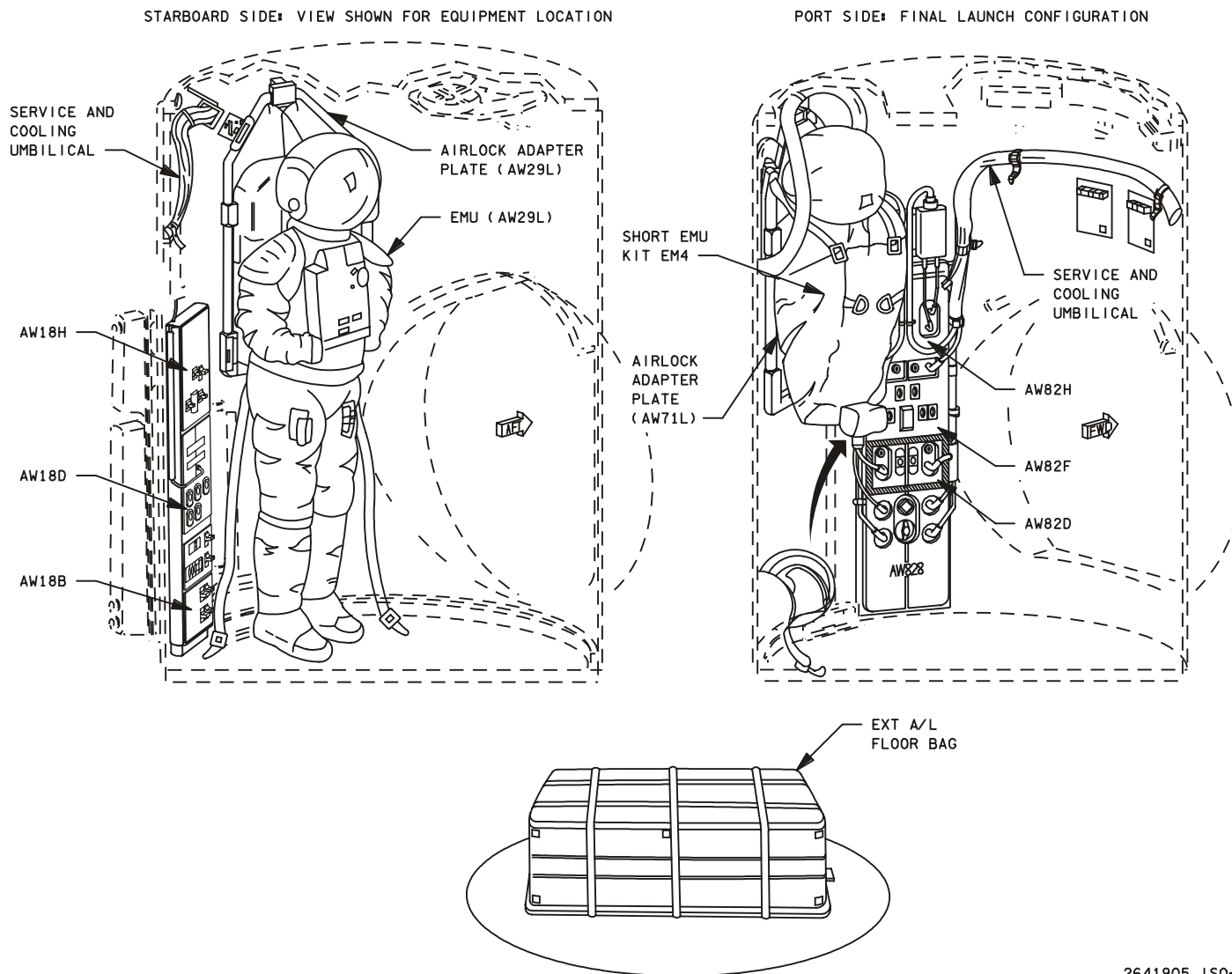

Figure 4-2. Airlock equipment and associated location codes

2641905. ISO, 1

5.0 PRACTICE EXERCISE

For each location code, fill in the blanks in the table below with the crew compartment, surface, and grid coordinates (if applicable):

Code	Crew compartment	Surface	Location grid coordinates
Example: AW30B	<u>Airlock</u>	<u>Wall</u>	<u>30%</u> of circumference from FWD hatch centerline (cw) <u>~12</u> inches from <u>overhead</u> surface
Example: F7	<u>Flight deck</u>	<u>Forward</u>	
MD40C	_____	_____	_____ of surface width from _____ side
AW90D	_____	_____	~ _____ inches from _____ of surface
O11	_____	_____	_____ of circumference from FWD hatch centerline (cw)
MO10E	_____	_____	~ _____ inches from _____ surface
S2	_____	_____	_____ of surface width from _____ side
W2	_____	_____	~ _____ inches from _____ of surface
AD7A	_____	_____	
MR12B	_____	_____	_____ of surface width from _____ side
A13	_____	_____	~ _____ inches from _____ of surface
AO8C	_____	_____	
R2D2	_____	_____	

5.1 PRACTICE EXERCISE ANSWERS

Code	Crew compartment	Surface	Location grid coordinates
AW30B	<u>Airlock</u>	<u>Wall</u>	<u>30%</u> of circumference from FWD hatch centerline (cw) <u>~12</u> inches from <u>overhead</u> surface
F7	<u>Flight deck</u>	<u>Forward</u>	
MD40C	<u>Middeck</u>	<u>Deck</u>	<u>40%</u> of surface width from <u>left</u> side <u>~18</u> inches from <u>top</u> of surface
AW90D	<u>Airlock</u>	<u>Wall</u>	<u>90%</u> of circumference from FWD hatch centerline (cw) <u>~24</u> inches from <u>overhead</u> surface
O11	<u>Flight deck</u>	<u>Overhead</u>	
MO10E	<u>Middeck</u>	<u>Overhead</u>	<u>10%</u> of surface width from <u>left</u> side <u>~30</u> inches from <u>top</u> of surface
S2	<u>Flight deck</u>	<u>Seat (PLT)</u>	
W2	<u>Flight deck</u>	<u>Window</u>	
AD7A	<u>Airlock</u>	<u>Deck</u>	
MR12B	<u>Middeck</u>	<u>Right</u>	<u>12%</u> of surface width from <u>left</u> side <u>~12</u> inches from <u>top</u> of surface
A13	<u>Flight deck</u>	<u>Aft</u>	
O08C	<u>Airlock</u>	<u>Overhead</u>	
R2D2	<u>N/A</u>	<u>N/A</u>	<u>(Not an orbiter code)</u>